

Dow Corning

EIFS Restoration Guide

DOW CORNING

The logo consists of the text "DOW CORNING" in a serif font, italicized, centered within a black rectangular box. Below this box is a solid gray rectangular bar.

This document is intended to provide installation and field testing instructions for *Dow Corning*[®] brand sealants, coatings and primers for EIFS applications in order to provide building owners the longest lasting weatherproofing system available. While this guide provides product-specific EIFS restoration procedures, the recommendations in this guide are not intended to replace those of a qualified industry consultant or engineer who can investigate and evaluate the existing condition of a particular EIFS building.

Contents

Introduction	2
EIFS Joint Failure Overview	3
Adhesive Failure of Sealant	3
Sealant Deterioration	3
Cohesive Failure of Sealant	3
Delamination of the EIFS Coating	3
Products for EIFS Restoration	5
Silicone Weatherproofing Sealants	5
Prefabricated Silicone Seal	5
Waterproof Coatings	5
Primers	5
EIFS Restoration Methods	6
Recessed Joint	6
Joint Removal	6
Joint Reconstruction	6
Joint Overlay	7
Wall Restoration	7
EIFS Restoration Procedures	8
Recessed Joint	8
Joint Removal	9
Joint Reconstruction	10
Joint Overlay	11
Field Adhesion Test Procedures	13
For <i>Dow Corning</i> [®] 123 Silicone Seal	13
For <i>Dow Corning</i> [®] AllGuard Silicone Elastomeric Coating	15
Warranties	16
References	17

Introduction

The purpose of this guide is to discuss why and how to use *Dow Corning*[®] brand sealants, *Dow Corning*[®] 123 Silicone Seal and *Dow Corning*[®] AllGuard Silicone Elastomeric Coating for the restoration of Exterior Insulation and Finish Systems (EIFS) and joints within or adjacent to the EIFS. Dow Corning offers a systems approach to the restoration of EIFS that cannot be matched by any other manufacturer. Rather than a temporary fix, the Dow Corning EIFS Restoration System offers long-term waterproofing solutions to leaking EIFS buildings.

The recommendations in this guide are not intended to replace those of a qualified industry consultant or engineer who can investigate and evaluate the existing condition of a particular EIFS building. Problems associated with EIFS can be complex and may not be repaired through improved waterproofing of the building facade alone. Water penetration through faulty joints or at terminations of the EIFS may cause substantial damage in the EIFS or the underlying structure that must be addressed separately from the waterproofing. Addressing certain design flaws such as the failure to allow proper water drainage from a window system, overheating of expanded polymer styrene (EPS) insulation, or excessive deflections due to poor foundations are beyond the scope of this document. It is strongly encouraged that a qualified industry consultant be hired in these cases.

In the following sections, various EIFS restoration alternatives will be discussed. Since no single method is best for all situations, each restoration method should be considered. To assist in determining which restoration method is best, a mockup of the restoration method or methods should be installed on the building. Dow Corning will assist at the job site to help determine which restoration method is best suited for each particular building.

Silicones Are Better

- *Dow Corning* one-component silicone sealants do not require special mixing, unlike multicomponent polyurethane sealants.
- *Dow Corning* silicone sealants have been tested and recommended by most major EIFS manufacturers for use with their systems.
- *Dow Corning* silicone sealants are UV stable and are virtually unaffected by outdoor weathering. Silicone sealants have a life expectancy of greater than 20 years compared to 5 to 10 years of life expectancy for many organic polyurethane sealants.
- *Dow Corning*[®] 790 Silicone Building Sealant, the preferred sealant for EIFS expansion joints, has unparalleled ultra-low modulus properties, movement capability of +100/-50 percent and a proven 20+ year performance on buildings.
- Inorganic silicone sealants have more stable modulus and remain flexible in cold temperatures as compared to organic polyurethane sealants which stiffen in cold temperatures. The following graph compares the modulus of *Dow Corning* 790 Silicone Building Sealant with a multicomponent polyurethane at room temperature and cold conditions:

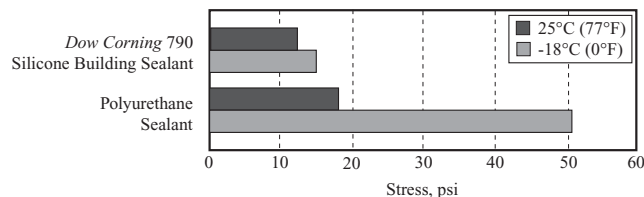

Modulus is determined at 25 percent elongation in a 1/2" x 1/2" (13 mm x 13 mm) tensile adhesion joint pulled at 2"/min (51 mm/min). Cured samples were conditioned for 24 hours prior to testing.

EIFS Joint Failure Overview

Because EIFS joints may fail for several reasons, the failure mode of the sealant joint should be examined to determine which restoration method is feasible or preferred. The following sections describe the four basic types of sealant joint failures and their possible causes.

Adhesive Failure of Sealant

Adhesive failure is a loss of bond or adhesion of the sealant to a substrate. This failure may occur for three primary reasons: improper use of primer, failure to use a primer or improper surface preparation. If field adhesion testing had been performed at installation, the results should have dictated surface preparation requirements. Most sealants require the use of a primer. If testing indicates that a specific primer should be used, failure to use that primer or improper use of the primer may cause adhesive failure.

Adhesive failure may also be the result of an improperly prepared substrate. The substrate must always be clean, dry and frost-free prior to sealant installation. Adhesion may be reduced if the EIFS coating is not fully dry. An improperly prepared substrate is a common source of adhesive failure of sealant in a joint.

Sealant Deterioration

Up until the past several years, multicomponent polyurethane sealants were used on most EIFS buildings. Polyurethane sealants are organic materials that deteriorate in the presence of ultraviolet light. This deterioration manifests itself in loss of sealant flexibility and movement capability, or in some instances, reversion of the sealant from a cured to an uncured state. It is not uncommon for polyurethane-sealed joints to experience sealant failure within 5 to 10 years. Total sealant deterioration or reversion of a polyurethane sealant is one of the most difficult joint failure modes in EIFS to restore.

Deterioration in the form of hardening of the sealant will cause a greater stress to be exerted at the bondline with each extension and compression. This will typically manifest itself in adhesive failure caused by

the greater stress or cohesive failure in the EIFS because the EIFS structure can be weaker than the force exhibited. These are among the most common type failures.

Cohesive Failure of Sealant

Cohesive failure occurs when a sealant tears or splits within itself as the result of joint movement. Cohesive failure is usually the result of the sealant no longer being able to accommodate the expansion and contraction of the joint. A sealant is expected to have a certain movement capability as determined by the sealant manufacturer. Sealants are either designated by categories of $\pm 12\frac{1}{2}$ percent, ± 50 percent or $+100/-50$ percent initial movement capability. However, many polyurethane sealants will stiffen and show a loss in movement capability over time. As a result, joint movement may cause cohesive failure of a stiffened sealant.

Joint movement on a percentage basis is also affected by the size of the joint. For example, $\frac{1}{4}$ " (6-mm) movement on a $\frac{1}{2}$ " (13-mm) wide joint will be twice as much on a percentage basis as a $\frac{1}{4}$ " (6-mm) movement on a 1" (25-mm) wide joint. Therefore, narrower joints are more prone to cause failure of the sealant.

Cohesive failure may be the result of the sealant joint profile. The ideal joint profile might be viewed as the compromise between two undesirable extremes. Lesser sealant depth allows for greater movement capability of the sealant, but because organic sealants may degrade on the surface, the joint is susceptible to cohesive failure. Thicker sealant depth ensures compensation for weathering of the sealant surface but reduces sealant movement capability and increases the forces exerted on the joint and the potential for joint failure.

Delamination of the EIFS Coating

Excessive sealant depth will reduce movement capability of the sealant, increasing the potential for substrate failure.

Delamination occurs when the sealant overstresses the coating. This can happen at any time, but is particularly prone to occur when the EIFS coating is softened by prolonged exposure to moisture or water. Delamination of the EIFS coating can often be attributed to the incorrect use of open-cell polyurethane backer rod. The absorptive nature of open cell polyurethane backer rod allows moisture to continuously contact the EIFS coating causing softening of the EIFS coating and increasing the potential for delamination during joint extension. EIFS requires the use of closed-cell polyethylene or non-gassing polyolefin backer rods to perform successfully.

Until recently, EIFS manufacturers specified that their acrylic finish coat be applied into the joint. This coating is particularly vulnerable to softening when wet, and as a result, finish coat delamination is a common source of EIFS joint failure. EIFS manufacturers now require that the finish coat be stopped at the face of the joint and that the sealant be applied to the more moisture-stable basecoat or an acrylic paint color primer on the basecoat. Both the basecoat and color primer are more stable in a wet environment and are less susceptible to delamination when stressed by a sealant during joint extension.

The other significant factor contributing to EIFS coating delamination is the modulus or stiffness of the sealant. As previously discussed, some sealants, and especially some polyurethane sealants, stiffen with age. A polyurethane sealant that may initially be low modulus might become noticeably less flexible after weathering.

Polyurethane sealants also have the inherent property of increasing 2 to 3 fold in sealant modulus in cold temperatures. This is a particular disadvantage with EIFS because in cold temperatures, a joint has its greatest extension. A polyurethane sealant becomes a stiff, high modulus sealant in cold temperatures creating a tremendous amount of stress on the EIFS coating. The combination of a soft EIFS coating and a stiff polyurethane sealant in cold temperatures is a probable cause of most finish coat delamination and joint failure in EIFS.

Products for EIFS Restoration

Silicone Weatherproofing Sealants

Dow Corning[®] 790 Silicone Building Sealant is the premium expansion joint sealant for EIFS. With ultra-low modulus, high movement capability of +100/-50 percent, *Dow Corning* 790 Silicone Building Sealant can perform in joints where other sealants would fail. This sealant is intended for EIFS-to-EIFS joints and requires the use of a *Dow Corning*[®] brand primer for all EIFS applications. Consult your *Dow Corning* representative for specific EIFS systems tested and approved. *Dow Corning* 790 Silicone Building Sealant is available in 11 standard colors and pre-matched custom colors for EIFS.

Dow Corning[®] 791 Silicone Weatherproofing Sealant is a low-cost, high-performance sealant intended for EIFS-to-metal application and expansion joints with certain EIFS systems. This sealant features ± 50 percent movement capability and primerless adhesion to most EIFS manufacturers' systems. *Dow Corning* 791 Silicone Weatherproofing Sealant is available in seven standard colors.

Dow Corning[®] 795 Silicone Building Sealant is a high-performance sealant intended for use at EIFS perimeters and certain EIFS expansion joints. The sealant features excellent primerless adhesion to most EIFS systems. *Dow Corning* 795 Silicone Building Sealant is available in 11 standard colors and pre-matched custom colors for EIFS.

Since EIFS manufacturers do not permit the use of open-cell polyurethane backer rod with their systems, use either *Dow Corning* 791 Silicone Weatherproofing Sealant or *Dow Corning* 795 Silicone Building Sealant in joints where the EIFS is adjacent to nonporous or metal surfaces.

Prefabricated Silicone Seal

Dow Corning[®] 123 Silicone Seal is the key product in the *Dow Corning* EIFS Restoration System. This pre-fabricated silicone strip, when used in conjunction

with *Dow Corning* 795 Silicone Building Sealant as an adhesive and *Dow Corning* AllGuard Silicone Elastomeric Coating, provides a low-cost, long-term waterproofing system for EIFS buildings. The ultra-low modulus *Dow Corning* 123 Silicone Seal, which features movement capability of +200/-75 percent, produces minimal stress on an EIFS finish coat (3 psi [0.021 MPa] at 25 percent elongation). *Dow Corning* 123 Silicone Seal can be textured and custom designs can be provided to your specifications.

Waterproof Coatings

Dow Corning[®] AllGuard Silicone Elastomeric Coating is a 100 percent silicone latex water-based elastomeric coating intended for the waterproofing of masonry, stucco and EIFS buildings. Unlike acrylic elastomeric coatings, *Dow Corning* AllGuard Silicone Elastomeric Coating offers the long-term weatherability and flexibility of *Dow Corning* silicone sealants. This coating is available in 55 standard colors and a full range of custom colors that are made to order at your distributor's facility. *Dow Corning* AllGuard Silicone Elastomeric Coating, when used in conjunction with *Dow Corning* 123 Silicone Seal, offers unlimited color flexibility in waterproofing an EIFS building.

Primers

Dow Corning[®] 1200 Prime Coat is a solvent-based, adhesion-promoting primer intended to be used with *Dow Corning* sealants. *Dow Corning* 1200 Prime Coat is compatible with EIFS and can also be used on adjacent metal if priming is required.

Dow Corning[®] P5200 Adhesion Promoter is a mixture of air-drying, moisture-reactive materials diluted in a non-VOC volatile methylsiloxane fluid designed to improve the adhesion of a wide variety of *Dow Corning* sealants to most metals, glass, ceramics, wood, concrete and many plastics.

EIFS Restoration Methods

Four restoration methods are offered for the repair and restoration of EIFS and EIFS joints. Any of the four methods may be appropriate for your specific building. The failure mode of the existing sealant joint will help to dictate which is the most cost-effective and practical restoration method. Mockups of the selected methods should be installed to help determine appropriateness of each repair method. Dow Corning will assist you in helping you make this determination. Certain restoration methods will require the assistance of an EIFS manufacturer.

Following is an overview of each restoration method and a discussion of the advantages and disadvantages of each method. The following section includes the specific procedures for each restoration method.

Recessed Joint

In situations where the failed existing joint has been recessed into the joint, it is possible to install a new sealant joint over the old sealant joint without removing the failed sealant. The existing sealant must be recessed at least 1/2" (13 mm) from the face of the joint to allow a new sealant joint to be installed. Recess of greater than 1/2" (13 mm) may allow a closed-cell backer rod or foam tape to be installed. Slit the existing sealant before applying a bond breaker tape over it in the joint. (See Figure 1, page 8.)

The advantage of this method is that the joint can be made watertight without changing the appearance of the joint. Also, this method is fairly cost-effective since removal of the old sealant is not required.

A potential disadvantage of this procedure results from the finish coat having likely been installed into the joint. Any new sealant will probably be installed to the finish coat unless the additional step of removing the finish coat of the EIFS is performed. *Dow Corning* sealants have excellent adhesion to both finish and base coats of EIFS. While Dow Corning is not responsible for the integrity of the EIFS coating and potential delamination of the EIFS coating under stress, the use of a low-modulus silicone, such as *Dow Corning 790 Silicone Building Sealant*, will ensure the best possible joint performance.

Joint Removal

The joint removal restoration method includes complete removal of all existing sealant and installation of new sealant. The challenging aspect of this procedure is the removal of the old sealant.

Removal of a reverted polyurethane sealant becomes very costly and time consuming due to the gummy nature of the deteriorated organic sealant. The gummy sealant is extremely difficult to remove from EIFS substrates without the use of solvents, which can damage the underlying foam insulation board. The EIFS cannot be easily abraded without causing damage to the coating and mesh. If the mesh is damaged, reconstruction of the joint will be required.

If joint failure is due to finish coat delamination and the sealant is not reverted or gummy, joint removal may be more cost-effective than other methods.

Removal of a cured failed silicone sealant is much easier than the removal of a failed organic sealant. A silicone that is cured and has failed in adhesion on one side of the joint can be cleanly cut away from the other side of the joint with a knife, and the remainder abraded away.

It may be possible to remove the old sealant and finish coat without damaging the EIFS base coat and mesh. The use of knives, wire wheel abrasion and grinders may effectively remove the old sealant and finish coat. Job site mockup testing must be performed to evaluate the viability of this procedure. (See Figure 2, page 9.)

Joint Reconstruction

Reconstruction of an EIFS joint is the most costly and labor-intensive method of joint restoration. This method involves cutting into the EIFS and reinstalling EIFS base coat, mesh, color primer and/or finish coat to match the original joint condition. The EIFS manufacturer would be involved in supplying the procedures and appropriate EIFS coatings to match the existing coating. In lieu of the application of a new EIFS finish coating, *Dow Corning AllGuard Silicone Elastomeric Coating* from Dow Corning can be used to waterproof and coat the entire EIFS wall.

The reconstruction method would be appropriate if joints are sized too small to accommodate joint movement. The use of joint movement indicators can help assess whether joints are of sufficient width for a sealant to perform properly. Joint reconstruction also would be appropriate if a new penetration, such as a window, air conditioner, lighting fixture or other attachment, is being installed (see Figure 3, page 10). Joint reconstruction may also be necessary if the original EIFS design did not allow for the proper positioning of an expansion joint. It may be necessary for an EIFS manufacturer or industry consultant to evaluate this condition. In the reconstruction method, the sealant installation is as it would be with a new EIFS installation.

Joint Overlay

The joint overlay restoration method allows for waterproofing of joints in a cost-effective means that does not require reconstruction of the joint or removal of failed sealant. An overlay joint, commonly referred to as a bridge joint or band-aid joint, spans the existing sealant joint from the face of one side of the joint to the other. Traditionally, these joints have been applied in the field with a wet sealant such as *Dow Corning 795 Silicone Building Sealant*. Field-applied silicone overlay joints have a proven track record of performance on EIFS and other construction materials.

With the introduction of *Dow Corning 123 Silicone Seal*, the variability of field applied overlay joints has been eliminated. *Dow Corning 123 Silicone Seal* is the ideal choice for EIFS joint restoration. *Dow Corning 123 Silicone Seal* can provide a very cost-effective, watertight joint due to the labor savings associated with not having to remove the failed organic sealant. *Dow Corning 123 Silicone Seal* is applied directly over the failed joint using *Dow Corning 795 Silicone*

Building Sealant as the adhesive (see Figures 4 - 6, page 11). With the assistance of a Dow Corning representative, a field mockup can be installed to demonstrate the performance of this product with your system. When used in conjunction with *Dow Corning AllGuard Silicone Elastomeric Coating*, these Dow Corning products provide a complete silicone solution for failed EIFS joints.

Wall Restoration

Restoration of the EIFS wall beyond the existing joints can be complex, requiring the need for a qualified industry consultant who is experienced in EIFS restoration. Provided that the wall is essentially sound, waterproofing and restoring the wall can be accomplished with the use of *Dow Corning* sealants and *Dow Corning AllGuard Silicone Elastomeric Coating*.

When an EIFS wall is showing hairline cracks of $1/16$ " (1.6 mm) or less, *Dow Corning AllGuard Silicone Elastomeric Coating* can effectively bridge the hairline cracks and waterproof the wall. The *Dow Corning AllGuard Silicone Elastomeric Coating Application and Maintenance Guide*, Form No. 62-617, outlines the proper installation for *Dow Corning AllGuard Silicone Elastomeric Coating* on EIFS.

In areas where hairline cracks are in excess of $1/16$ " (1.6 mm) width, there may be need for a control or expansion joint at this location. An EIFS expert should be consulted in these cases. If a new joint cannot be installed by the joint reconstruction method, the use of an overlay joint is effective. For an irregular hairline crack, a field-applied wet sealant application with a *Dow Corning* sealant is recommended. *Dow Corning AllGuard Silicone Elastomeric Coating* then can be applied over the entire wall to ensure a watertight wall should further hairline cracks develop.

EIFS Restoration Procedures

Recessed Joint Restoration Procedure

This procedure is intended where the existing joints allow for a new sealant joint to be installed over the existing sealant joint. Prior to initiating sealant installation, a field adhesion test joint must be installed to verify sealant adhesion in the joint.

1. Clean the existing EIFS joint surface using a nonmetallic, stiff-bristle brush. Clean all adjacent metal surfaces with a solvent by the "two cloth" cleaning method. Any residue of the old sealant on the new joint surface must be completely removed. Mechanical abrasion with a wire brush may be necessary to remove old sealant residue. Blow all dust from the joint surface with oil-free compressed air.
2. Slit the existing sealant joint and apply a polyethylene or *Teflon*^{®1} bond breaker tape over the sealant. The bond breaker tape should be 1/2" (13 mm) wide or greater depending on the existing joint

width. A closed-cell foam bond breaker tape may be necessary to provide a maximum sealant depth of 3/8" (9 mm) for the tooled sealant.

3. Apply an appropriate *Dow Corning* primer to the EIFS and adjacent metal surfaces in a light coat using a soft-bristle brush or lint-free cloth. Avoid applying primer onto adjacent surfaces. Allow primer to dry before installing sealant.

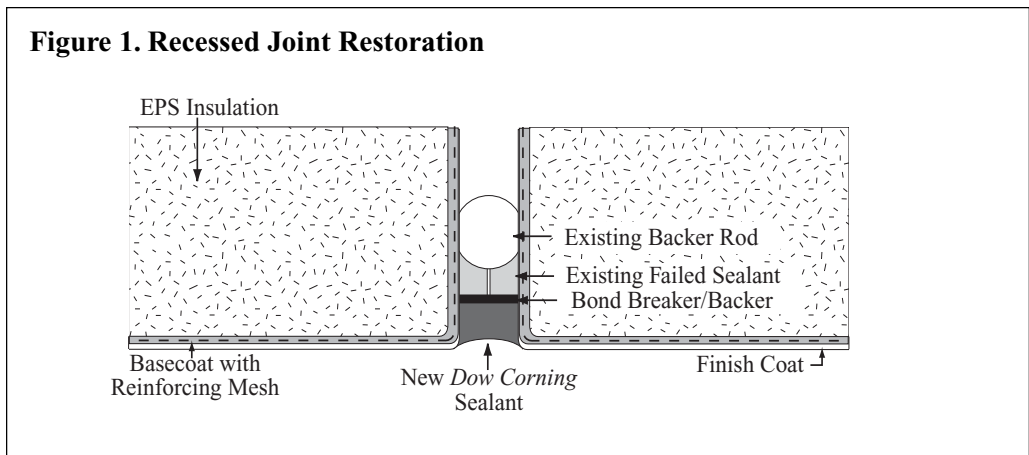

4. Install *Dow Corning* sealant to allow a minimum bond of 1/4" (6 mm) on the side of the joint. Sealant depth of 1/8" to 3/8" (3 to 9 mm) at the center of the joint is recommended.

¹*Teflon* is a registered trademark of E.I. du Pont de Nemours & Co.

Joint Removal Restoration Procedure

This procedure is best suited where joint failure is the result of finish coat delamination and the existing organic sealant has not reverted. Prior to initiating sealant installation, a field adhesion test joint must be installed to verify sealant adhesion in the joint.

1. Cut out as much of the existing sealant as possible. Remove and discard old backer rod.
2. Using mechanical abrasion, completely remove all traces of the existing sealant from the EIFS and adjacent metal surfaces. If present, remove the existing finish coat from the inside of the joint. The use of a diamond tipped grinder or mechanical wire wheel abrasion has proven successful for this use. Extreme care must be taken to avoid damaging the existing base coat and reinforcing mesh.

3. To remove all dust and loose particles, blow joints with oil-free compressed air. The joints must be thoroughly clean, dry and frost-free before installing sealant or additional base coat.
4. If base coat is damaged, it must be repaired with an appropriate EIFS base coat. An EIFS manufacturer must be consulted for advice in this situation. In most cases, the EIFS manufacturer

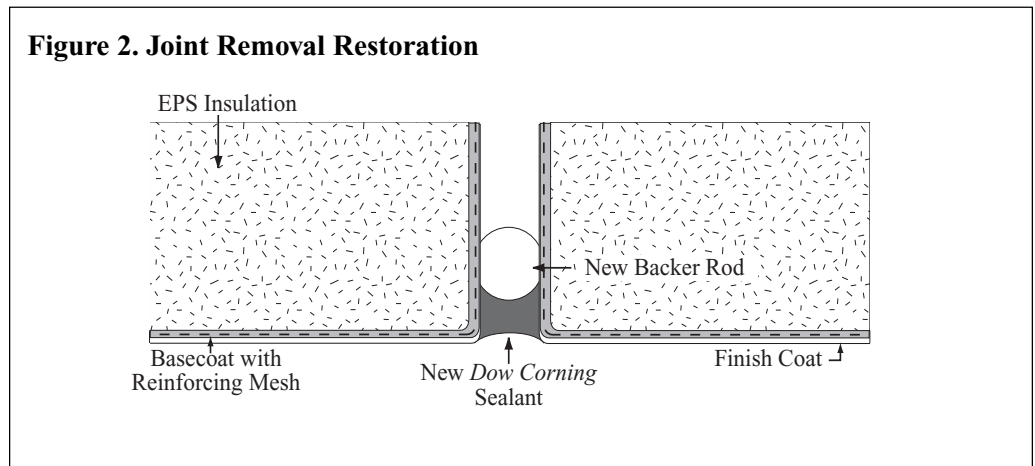

will recommend a colored primer for use over the base coat.

5. After EIFS coatings are allowed to dry, install *Dow Corning* primer, backer rod and *Dow Corning* sealant in accordance with *Dow Corning* guidelines.

Joint Reconstruction Restoration Procedure

This procedure can be used when replacing a failed sealant joint, widening a joint, adding a new expansion joint, creating a joint through the addition of a new opening in the wall or creating a new opening for an air conditioner. At all times follow the EIFS manufacturers' recommendations for the proper installation of their EIFS. This procedure is approved by the EIFS Industry Members Association (EIMA).

1. Cut through the EIFS with a sharp knife or saw so that damage to the EPS is minimal. Make this cut approximately 1/4" to 3/8" (6 to 9 mm) wider than the desired dimension of the new joint so that the sealant can be installed later.
2. Remove the unwanted EIFS materials and substrate and repair any damage to the EPS board.
3. The existing finish surrounding the new joint must be ground down to base for a space of 4" to 6" (102 to 152 mm) back from the edge of the joint so that new finish coat can be applied.
4. All substrates must be thoroughly dry, dust-free and frost-free before applying the new coating.
5. Apply new base coat to the exposed edge of the EPS board and onto the prepared face of the wall adjacent to the joint
6. Embed mesh into this new base coat making sure that the EPS board edge is completely protected and the mesh is brought onto the face of the wall where the finish has been removed.

7. Apply the EIFS manufacturer's colored primer to the inside of the joint if required and allow it to dry completely.
8. Install the EIFS finish coat to match the existing finish up to the edge of the joint. Due to the difficulty of matching the new finish with the existing, it may be necessary to recoat an entire wall section after modifications have been made.
Dow Corning AllGuard Silicone Elastomeric

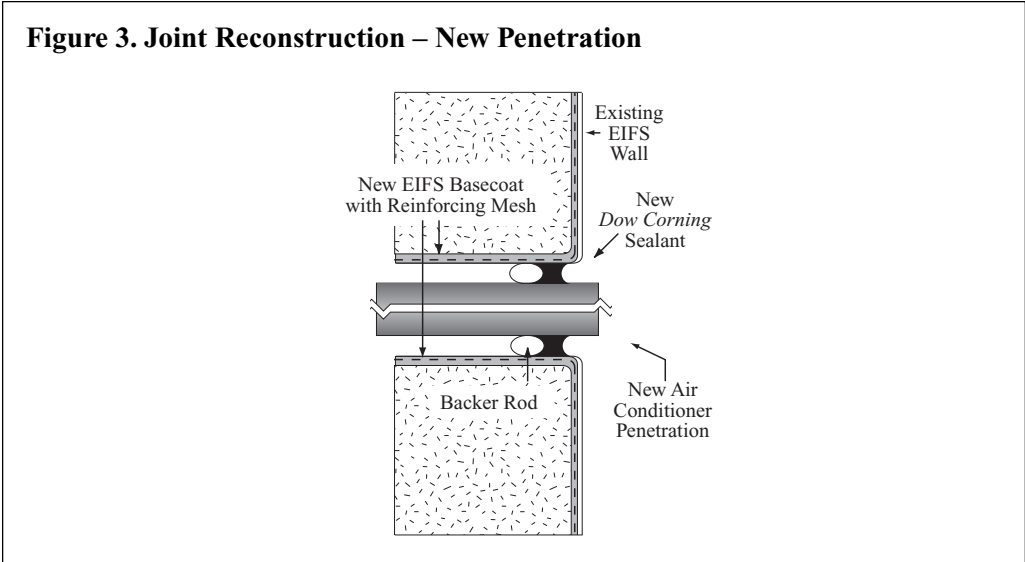

Coating can be used in lieu of an EIFS coating to provide a uniform finish and waterproofing of the EIFS wall.

9. Install *Dow Corning* primer, backer rod and *Dow Corning* sealant in accordance with *Dow Corning* guidelines. *Dow Corning AllGuard Silicone Elastomeric Coating* may be applied directly over cured *Dow Corning* sealant joints. Install *Dow Corning AllGuard Silicone Elastomeric Coating* in accordance with the *Dow Corning AllGuard Silicone Elastomeric Coating Application and Maintenance Guide*, Form No. 62-617.

Joint Overlay Restoration Procedure

This method is best suited when it is not feasible to remove failed sealant without damaging the EIFS. An overlay joint may be installed with a *Dow Corning* sealant alone or utilizing *Dow Corning* 123 Silicone Seal with *Dow Corning* 795 Silicone Building Sealant as an adhesive. Refer to the *Dow Corning AllGuard Silicone Elastomeric Coating Application and Maintenance Guide*, Form No. 62-617, and current product literature for more information. Prior to initiating sealant installation, a field adhesion test joint must be installed to verify sealant adhesion in the joint.

1. Using a nonmetallic, stiff-bristle brush, abrade the surface of the EIFS finish coat adjacent to the joint. Solvent clean any adjacent metal surface by the “two cloth” cleaning method. Blow all dust from the joint surface with oil-free compressed air.
2. Mask the surface of the EIFS to provide a clean edge for the overlay joint.
3. Slit the existing sealant joint. Apply a polyethylene or *Teflon* bond breaker tape over the existing sealant joint only if a wet sealant joint is to be installed. *Dow Corning* 123 Silicone Seal does not require a bond breaker tape.

4. If necessary, as determined through a field adhesion test joint, apply *Dow Corning* primer to the EIFS surface of the joint. (*Dow Corning* 790 Silicone Building Sealant typically requires primer on EIFS and metal; *Dow Corning* 791 Silicone Weatherproofing Sealant and *Dow Corning* 795 Silicone Building Sealant typically do not require primer on these substrates.)

Figure 4. Joint Overlay Restoration Using *Dow Corning* Sealant

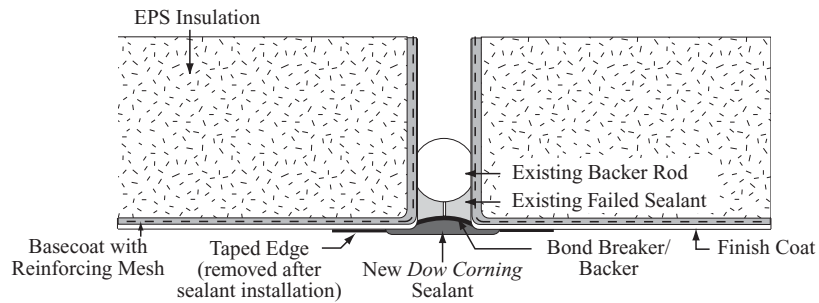

Figure 5. Joint Overlay Restoration – Fillet Joint at Window Perimeter

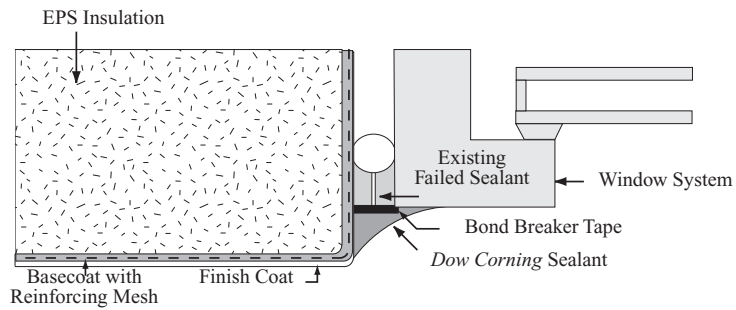
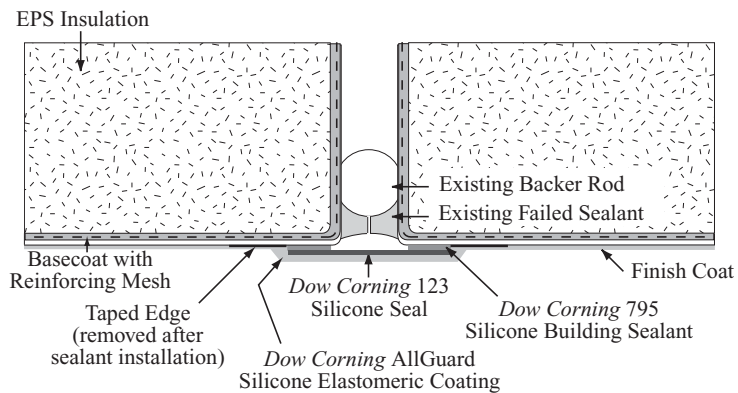

Figure 6. Joint Overlay Restoration Using *Dow Corning* 123 Silicone Seal and *Dow Corning* AllGuard Silicone Elastomeric Coating



5. When installing a wet sealant overlay joint, apply and tool sealant in a flat strip or fillet bead over the old joint and onto each side of the joint a minimum of $\frac{3}{8}$ " (9 mm). Sealant depth after tooling should be a nominal $\frac{1}{4}$ " (6 mm) with a maximum depth of $\frac{3}{8}$ " (9 mm). Special plastic tooling devices can be used to provide a uniform joint profile. Refer to the figures shown for typical applications.
6. When installing *Dow Corning* 123 Silicone Seal, select a width that will allow a minimum of $\frac{3}{8}$ " (9-mm) bond on each side of the joint. Apply *Dow Corning* 795 Silicone Building Sealant in approximately $\frac{1}{4}$ " (6-mm) diameter beads to each side of the joint. Within 10 minutes of sealant application, press the extrusion onto the sealant using a roller to provide consistent pressure and ensure uniform contact. Remove masking tape and excess sealant. Refer to Figure 6 for a typical application.
7. *Dow Corning* AllGuard Silicone Elastomeric Coating can be applied directly over any cured *Dow Corning* sealant or *Dow Corning* 123 Silicone Seal. Job site adhesion testing should be performed to verify adhesion of *Dow Corning* AllGuard Silicone Elastomeric Coating to the existing EIFS.

Field Adhesion Test Procedures

Field Adhesion Tests for Use with *Dow Corning*[®] 123 Silicone Seal

Two field adhesion tests can be performed to detect field problems such as improper cleaning, use of improper primer, poor primer



application or other problems that may affect adhesion. Neither is a precise, scientific test, but both are useful as screening procedures.

Field Adhesion Test

As a check for adhesion, a simple hand pull test may be run on the job site after the *Dow Corning*[®] 795 Silicone Building Sealant is fully cured (usually within 7-21 days).

1. Make a knife cut horizontally across the *Dow Corning*[®] 123 Silicone Seal.
2. Make a vertical cut from the horizontal cut approximately 1" (25-mm) long down through the middle of the *Dow Corning* 795 Silicone Building Sealant on both sides of the joint opening.
3. Grasp the 1" (25-mm) piece of *Dow Corning* 123 Silicone Seal and pull at a 90° angle. Do not destroy the silicone seal; it can be repaired later.
4. The pass-fail criterion is cohesive failure of the *Dow Corning* 795 Silicone Building Sealant.

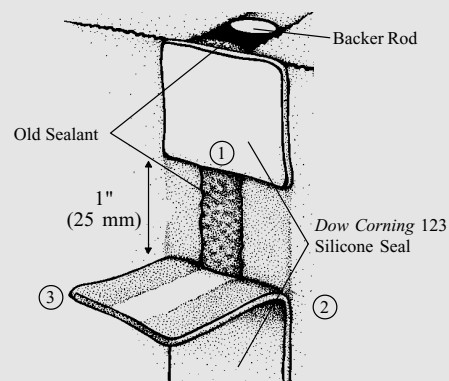

1. Horizontal cut across silicone seal
2. Vertical cut down through *Dow Corning* 795 Silicone Building Sealant
3. Grasp the silicone seal and pull at 90° angle, peeling down another 2" (51 mm)

Test Area Repair

The silicone seal can be easily repaired by applying more sealant in the peeled off areas and rolling the seal back into the wet sealant. At the horizontal cut, apply sealant in this butt joint and smooth.

Alternate Field Adhesion Test

This alternative screening may be done on a flat test surface like that shown at right.

1. The surface should be cleaned and primed following the recommended procedures for the specific project.
2. A piece of polyethylene sheet or bond breaker tape should be placed across the flat test surface.
3. An approximately 4" (102-mm)-long strip of *Dow Corning* 123 Silicone Seal should be applied using *Dow Corning* 795 Silicone Building Sealant. At least 2" (51 mm) of the silicone strip should be applied over the polyethylene sheet or tape.
4. After the sealant has completely cured (7-21 days), conduct the hand pull test, beginning with step 3 as shown above in the Field Adhesion Test procedure.

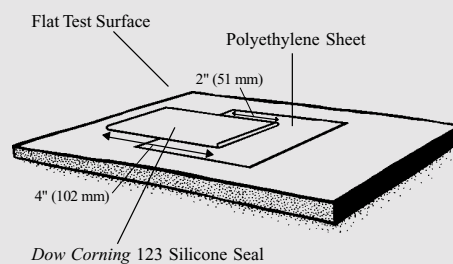

NOTE: It may be desirable to immerse the test piece in water for 1-7 days (after complete sealant cure) and repeat the pull procedure above.

Adhesion Test Log

The information obtained from these tests should be recorded on a field adhesion test log similar to the example below. This log should be retained as part of the Dow Corning limited warranty procedure.

Field Adhesion Testing Log

Project:				Product Tested: <i>Dow Corning</i> 123 Silicone Seal		
Location:				Sealant: <i>Dow Corning</i> 795 Silicone Building Sealant		
				Primer (if applicable):		
Date of Test	Location of Test (Floor)	Date of Installation	<i>Dow Corning</i> 123 Silicone Seal Lot No.	Sealant Lot No.	Primed (Yes/No)	Acceptable Adhesion (Y/N)
S A M P L E						

Field Adhesion Tests for Use with *Dow Corning*[®] AllGuard Silicone Elastomeric Coating

1. Prepare surfaces as described in the *Dow Corning AllGuard Silicone Elastomeric Coating Application and Maintenance Guide*, Form No. 62-617.
2. Apply the primer per the application method and allow to dry.
3. Apply the first coat of *Dow Corning AllGuard Silicone Elastomeric Coating* at a rate of 10 to 12 mils (0.25 to 0.30-mm) wet film thickness. Imbed a cheesecloth strip (1" x 12" [25 x 305 mm]) in the wet coating with a paint brush.
4. Apply the second coat over the cheesecloth at the same 10 to 12 mils (0.25 to 0.30-mm) wet film thickness and allow to fully cure for 7 to 14 days.
5. Test adhesion of the coating by pulling the uncoated part of the cheesecloth at a 180° angle at a slow, steady rate.
6. Inspect and note the percent cohesive failure (percent of coating material left on the wall surface). At least 80 percent of the coating should remain on the substrate. If the 80 percent retention is not achieved, reclean and test another suitable section. If necessary, contact your Dow Corning representative or Dow Corning Customer Service for further instruction.

Figure 7: Test Procedure Diagram

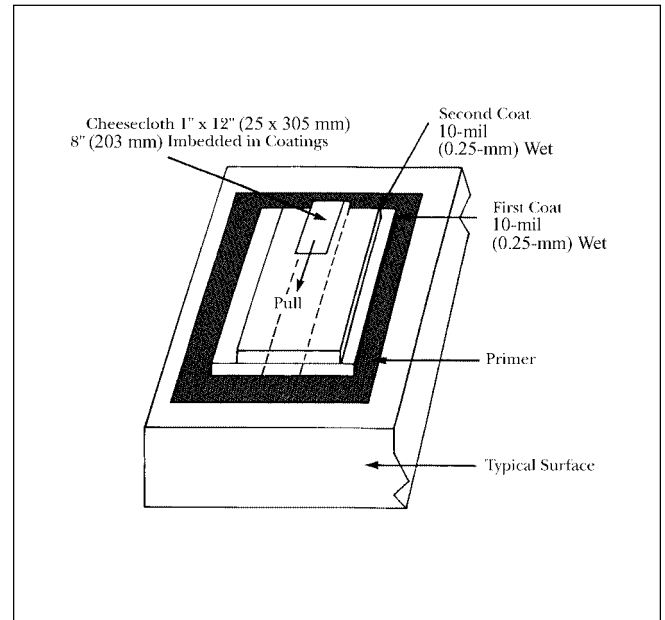

Warranties

Weatherseal Limited Warranty

This warranty is given when Dow Corning silicone building sealants are used in non-structural applications, for example, perimeter seals, weatherseals, splices, internal seals, etc.

Dow Corning brand building sealants carry a 20-year Weatherseal Limited Warranty. Testing is required to obtain these warranties if the surface is not recommended by Dow Corning.

To qualify for warranty coverage, the sealant must be applied according to published Dow Corning guidelines.

Dow Corning's Weatherseal Limited Warranties are applicable to both new and remedial projects. Because remedial projects differ greatly, please contact your local Dow Corning representative or distributor for assistance in defining your sealant application requirements.

Dow Corning 123 Silicone Seal Warranty

A 10-year project specific warranty is available for *Dow Corning 123 Silicone Seal*, used with the sealant, and *Dow Corning AllGuard Silicone Elastomeric Coating* (optional). Instructions for proper application procedures to qualify for a warranty are found in the *EIFS Application Guide*, Form No. 64-412, and the *Dow Corning AllGuard Silicone Elastomeric Coating Application and Maintenance Guide*, Form No. 62-617.

Testing Requirements for Weatherseal Limited Warranty and *Dow Corning 123 Silicone Seal Warranty*

Dow Corning publishes guidelines that provide general recommendations for products on a wide variety of substrates. For this warranty to apply, project specific testing is required for surfaces not listed, and surfaces listed but not recommended.

Testing is particularly important in determining sealant compatibility with a non-silicone gasket or setting block. Additionally, adhesion testing must be performed in the field to confirm laboratory and/or general recommendations.

Dow Corning AllGuard Silicone Elastomeric Coating Warranty

A 10-year project specific warranty is available for *Dow Corning AllGuard Silicone Elastomeric Coating*. To qualify for the warranty, the product must be applied according to the instructions in the *Dow Corning AllGuard Silicone Elastomeric Coating Application and Maintenance Guide*, Form No. 62-617, and 10 dry mils (0.25 mm) coverage must be verified. In addition, if the coating is applied without a primer, field adhesion testing must be done and documented as part of the warranty application process. This testing must be done prior to the start of the project.

References

Dow Corning AllGuard Silicone Elastomeric Coating Application and Maintenance Guide, Dow Corning Corporation, Midland, MI, 2002.

EIMA Guide for Use of Sealants with Exterior Insulation and Finish Systems, Class PB; EIFS Industry Members Association (EIMA), Clearwater, FL, May 1994.

Klosowski, Jerome M., *Sealants in Construction*, Marcel Dekker, Inc., New York, 1989.

Schwartz, Thomas A., editor, *Water in Exterior Building Walls: Problems and Solutions*, ASTM STP 1107, American Society for Testing and Materials, Philadelphia, 1991.

Sealants: The Professionals' Guide, Sealant, Waterproofing & Restoration Institute, 1995.

Thomas, Robert G. Jr., *Exterior Insulation and Finish System Design Handbook*; CMD Associates, Inc., Seattle, Washington, 1992.

Williams, Mark F. and Barbara Lamp Williams, *Exterior Insulation and Finish Systems: Current Practices and Future Considerations*, ASTM Manual Series: MNL 16, American Society for Testing and Materials, Philadelphia, 1994.

Williams, Mark F. and Richard G. Lampo, editors, *Development, Use and Performance of Exterior Insulation and Finish Systems (EIFS)*, ASTM STP 1187, American Society for Testing and Materials, Philadelphia, 1995.

How to Contact Us

Dow Corning has sales offices and manufacturing sites as well as science and technology laboratories around the globe. Telephone numbers of locations near you are available on the internet at www.dowcorning.com, or by calling one of our primary locations listed here.

Your Global Connection

Asia

Dow Corning Asia Ltd. – Japan
Tel +81 3 3287 1151

Dow Corning Asia – Singapore
Tel: +65 253 6611

Australia & New Zealand

Dow Corning Australia Pty. Ltd.
Tel: +61 1300 360 732

Europe

Dow Corning Europe
Tel: +32 64 88 80 00

North America

Dow Corning Corporation
World Headquarters
Tel: +1 989 496-6000

South America

Dow Corning do Brasil
Tel: +55 11 3759 4300

Handling Precautions

PRODUCT SAFETY INFORMATION REQUIRED FOR SAFE USE IS NOT INCLUDED IN THIS DOCUMENT. BEFORE HANDLING, READ PRODUCT AND MATERIAL SAFETY DATA SHEETS AND CONTAINER LABELS FOR SAFE USE, PHYSICAL AND HEALTH HAZARD INFORMATION. THE MATERIAL SAFETY DATA SHEET IS AVAILABLE FROM YOUR DOW CORNING REPRESENTATIVE, OR DISTRIBUTOR, OR BY CALLING YOUR GLOBAL DOW CORNING CONNECTION.

Limited Warranty Information – Please Read Carefully

The information contained herein is offered in good faith and is believed to be accurate. However, because conditions and methods of use of our products are beyond our control, this information should not be used in substitution for customer's tests to ensure that Dow Corning's products are safe, effective, and fully satisfactory for the intended end use. Suggestions of use shall not be taken as inducements to infringe any patent.

Dow Corning's sole warranty is that the product will meet the Dow Corning sales specifications in effect at the time of shipment.

Your exclusive remedy for breach of such warranty is limited to refund of purchase price or replacement of any product shown to be other than as warranted.

DOW CORNING SPECIFICALLY DISCLAIMS ANY OTHER EXPRESS OR IMPLIED WARRANTY OF FITNESS FOR A PARTICULAR PURPOSE OR MERCHANTABILITY.

DOW CORNING DISCLAIMS LIABILITY FOR ANY INCIDENTAL OR CONSEQUENTIAL DAMAGES.

DOW CORNING

**WE HELP YOU INVENT
THE FUTURE.™**

www.dowcorning.com

Dow Corning is a registered trademark of Dow Corning Corporation.
WE HELP YOU INVENT THE FUTURE is a trademark of Dow Corning Corporation.

©1996, 1999, 2002 Dow Corning Corporation. All rights reserved.

Printed in USA

AGP6102

Form No. 62-510G-01