

Dow Corning[®] AllGuard Silicone Elastomeric Coating

Application and Maintenance Guide

DOW CORNING



Contents

This document is intended to provide installation and field testing instructions for *Dow Corning*[®] AllGuard Silicone Elastomeric Coating. Additional information regarding cleaning and maintenance is included to provide maximum, long-term waterproof performance for your building.

Product Description	1
Substrate Compatibility	1
Compatibility with <i>Dow Corning</i> [®] brand Products.....	1
Colors.....	1
Shelf Life	1
Application	2
Design Considerations	2
Figure 1: Drip Edge Design.....	2
Temperature and Humidity	2
Surface Preparation.....	2
Sealing Cracks	2
Workmanship.....	2
Priming	2
Table I: Surface Preparation	3
Table II: Estimated Application Rate	3
Coating.....	3
Drying Time.....	3
Disposal	3
Adhesion Test Procedure	4
Figure 2: Test Procedure Diagram	4
Cleaning and Maintenance	4
Limited Warranty	5

Product Description

Dow Corning[®] AllGuard Silicone Elastomeric Coating is a one-component water-based silicone elastomer designed to waterproof above-grade exterior masonry substrates. Featuring a smooth, matte finish, this coating is available in a broad range of standard and custom colors that are made to order at your distributor's location.

Ideal for both new construction and renovation projects, *Dow Corning* AllGuard Silicone Elastomeric Coating withstands wind-driven rain without water penetration.

Substrate Compatibility

Dow Corning AllGuard Silicone Elastomeric Coating is designed to waterproof above-grade exterior masonry substrates, such as concrete block, fluted block, brick, stucco, synthetic stucco, poured concrete, precast concrete, Exterior Insulation Finish Systems (EIFS), and previously coated masonry substrates.

Dow Corning AllGuard Silicone Elastomeric Coating generally has primerless adhesion to these substrates. Field adhesion testing is required at the site to ensure primerless results.

Compatibility with *Dow Corning*[®] Products

Dow Corning AllGuard Silicone Elastomeric Coating is compatible with the *Dow Corning*[®] products listed here. *Dow Corning* AllGuard Silicone Elastomeric Coating can be applied over the sealants after they have been allowed to achieve tack-free cure (see

sealant data sheets for specific cure times). It is the only coating that can be used for application over *Dow Corning*[®] 123 Silicone Seal. Products commonly used with *Dow Corning* AllGuard Silicone Elastomeric Coating include:

- *Dow Corning*[®] 123 Silicone Seal
- *Dow Corning*[®] 756 SMS Building Sealant
- *Dow Corning*[®] 790 Silicone Building Sealant
- *Dow Corning*[®] 791 Silicone Weatherproofing Sealant
- *Dow Corning*[®] 795 Silicone Building Sealant

When *Dow Corning* AllGuard Silicone Elastomeric Coating is used in conjunction with *Dow Corning* 123 Silicone Seal and these recommended sealants, complete building protection can be achieved.

Colors

Dow Corning AllGuard Silicone Elastomeric Coating is available in over 55 standard colors, and a full range of custom colors is available from your *Dow Corning* construction products distributor.

Shelf Life

Dow Corning AllGuard Silicone Elastomeric Coating has a shelf life of 6 months from date of manufacture.

Application

Design Considerations

As with any high-performance material, care taken in initial design and application will result in longer coating life.

In many building designs, there may be areas such as ledges and window sills that allow airborne dirt and soot to accumulate. If the design permits or promotes channeling of water runoff from these areas, dirt streaking is likely to result.

Wall texture and environmental conditions are also important factors in the quantity and type of dirt accumulated. Industrial areas and nearby highways increase the probability of soot and hydrocarbon in the air, resulting in a greater chance of dirt pickup and streaking. If the building's location, design, wall surface, or existing dirt streaking indicates channeling of water down the side of the wall, drip edges are recommended on the ledges, window sills, and scuppers to reduce dirt streaking on *Dow Corning AllGuard Silicone Elastomeric Coating*.

In field tests, the use of a drip edge greatly reduces or eliminates dirt streaking. The use of the drip edge moves the runoff water away from the wall, creating a non-patterned runoff.

A drip edge can be fabricated from the same material as the window sills or from other formable composites. The design of the drip edge should allow for a minimum 1" (25-mm) width for attachment to the ledge, with a bent edge of 15 to 45° or minimum 1/2" (13-mm) radius, with the edge at least 1/2" (13-mm) away from the wall (see Figure 1). The drip edge can be mechanically adhered to the substrate or attached with *Dow Corning 791 Silicone Weatherproofing Sealant* or *Dow Corning 795 Silicone Building Sealant*. A field adhesion test on the sealant to drip edge and sill must be performed to verify good adhesion.

Figure 1: Drip Edge Design

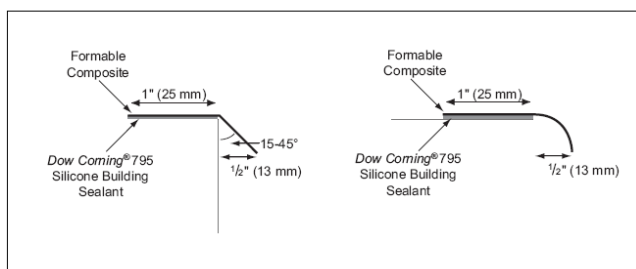

Temperature and Humidity

Dow Corning AllGuard Silicone Elastomeric Coating can be applied from 5 to 38°C (40 to 100°F). Do not apply if temperatures are forecasted to be below 5°C (40°F) within 24 hours after application. Do not apply the coating when the relative humidity is greater than 90 percent or when there is a threat of rain within 24 hours.

Surface Preparation

For recommendations to ensure proper cleaning and preparation of the substrate prior to coating, please refer to Table I.

Sealing Cracks

- Static cracks less than 1/16" (1.6 mm) can be bridged with *Dow Corning AllGuard Silicone Elastomeric Coating*.
- Static cracks greater than 1/16" (1.6 mm) must be repaired by methods suitable for the substrate before being coated with *Dow Corning AllGuard Silicone Elastomeric Coating*.
- Moving cracks should be stabilized or properly repaired for the expected movement prior to installation of *Dow Corning AllGuard Silicone Elastomeric Coating* to prevent tearing of the coating due to excessive movement.

Workmanship

- Protect adjacent surfaces and surroundings that are not to be coated.
- Apply a minimum of 2 coats to achieve a minimum thickness of ≥10 mils (0.25 mm) dry.
- Follow design considerations.

Priming (if needed)¹

One coat of primer is required.

1. Apply at a rate of 300 ft²/gallon (7.4 m²/L) using a 1/2 to 3/4" (13- to 19-mm) synthetic nap roller, nylon bristle brush, or airless sprayer.
2. Apply primer to the point of rundown.
3. Dry 30 minutes to 2 hours. Actual drying time will depend on temperature, humidity, and wind conditions. Allow an additional 30 minutes to dry after dry to the touch.
4. Apply coating over primer at least 30 minutes after primer is dry to the touch, but within 24 hours. If the surface cannot be coated during this time, care should be taken to ensure the primed surface is free of dirt and debris before applying coating.

¹ To determine if a primer is required, perform field adhesion tests as outlined on page 4 of this guide.

Table I: Surface Preparation¹

<u>Surface Conditions</u>	<u>Detection Method</u>	<u>Removal Method</u>
Efflorescence ²	Wipe with dark cloth	Wire brush; then clean with high-pressure water. On stubborn deposits, mix 1 part muratic acid (or similar) to 12 parts water; then clean with high-pressure water.
Dirt/Dust	Wipe with dark cloth	High-pressure water cleaning.
Laitance	Scrape with putty knife looking for powdery material	Scrape with steel scraping tool followed by high-pressure water cleaning.
Mildew	Visual	Scrub with 5 percent bleach solution followed by high-pressure water cleaning.
Grease/Oil	Sprinkle water on surface	Trisodium phosphate (TSP) solution in hot water and high-pressure water cleaning.
Form release, curing, or surface-hardening compounds	Visual; sprinkle water on the surface ³	Must be removed by mechanical abrasion or abrasive water cleaning.

¹ These are general recommendations; please refer to substrate manufacturer for specific remediation recommendations.

² Efflorescence may be caused by migration of water through a cementitious substrate reacting with components of the mix. Removing efflorescence may not prevent further formation of efflorescence at a later time without mitigating water migration within the substrate.

³ If water beads on the surface, the surface is contaminated. Apply a test treatment of detergent or caustic soda with a bristle brush to remove contamination. Retest. If water still beads, a penetrating water repellent may exist and will interfere with adhesion. Contact your Dow Corning Technical Service Representative for further recommendations.

Table II: Estimated Application Rate¹ (10-mil [0.25-mm] minimum dry film thickness)

<u>Texture/Substrate</u>	<u>Estimated Rate</u>	
	<u>ft²/gal</u>	<u>m²/L</u>
Smooth (brick, precast concrete)	70-80	1.7-2.0
Medium (sand, #3 vermiculite, stucco)	50-70	1.2-1.7
Coarse (aggregate, split face block, EIFS)	30-50	0.8-1.2

¹ Application rates vary tremendously with porosity and degree of texture on the substrate. These values are estimated and should be confirmed at the job site prior to bidding the project.

Coating

A minimum of two thick (10- to 12-mil) coats of *Dow Corning AllGuard Silicone Elastomeric Coating* are necessary to achieve the required 10-mil (0.25-mm) minimum dry film thickness to attain protection against through-water penetration and to qualify for a project-specific warranty.

Apply the coating in a minimum 10- to 12-mil (0.25-mm) wet thickness (see Table II for estimated application rates; a job-specific mockup is recommended to determine actual usage). Typically, two 10- to 12-mil (0.25-mm) wet coats will result in the required 10-mil (0.25-mm) dry coating thickness; however, an additional coat may be required due to surface texture or porosity. Apply using a ³/₄ to 1¹/₂" (19- to 38-mm) nap, polyester, or 50/50 polyester/wool blend roller cover, nylon bristle brush, or airless sprayer. When applying the coating with a roller, apply it in a fan pattern to

achieve uniform thickness. Always finish roller applications in the same direction to reduce visual surface texture differences.

Allow the coating to dry (typically 2 to 4 hours) before applying the next coat.

Note: Do not thin or cut back Dow Corning AllGuard Silicone Elastomeric Coating.

Drying Time

After the final coat has been applied, the average drying time is 4 to 8 hours, depending upon temperature, humidity, and wind conditions. *Dow Corning AllGuard Silicone Elastomeric Coating* will attain full adhesion and physical properties in 7 to 14 days.

Disposal

See the Material Safety Data Sheet (MSDS) for disposal information.

Adhesion Test Procedure

Field adhesion testing is required to obtain the project-specific warranty from Dow Corning. Tests must be made on all sides and different substrates of the building being coated. The locations and results are required on the warranty application.

1. Prepare surfaces as described in Table I.
2. Use of a primer is optional, but testing is required to ensure sufficient adhesion in primerless applications. If primer is used, apply per the application method and allow to dry.
3. Apply the first coat of *Dow Corning AllGuard Silicone Elastomeric Coating* at a rate of 10- to 12-mil (0.25- to 0.31-mm) wet film thickness. Imbed a cheesecloth strip (1" x 12" [25 x 305 mm]) in the wet coating with a paint brush.
4. Apply the second coat over the cheesecloth at the same 10- to 12-mil (0.25- to 0.31-mm) wet film thickness and allow to fully cure for 7 to 14 days. This is an adhesion test only; additional coats may be required to achieve thickness requirements.
5. Test adhesion of the coating by pulling the uncoated part of the cheesecloth at a 180° angle at a slow, steady rate.
6. Inspect and note the percent cohesive failure (percent of coating material left on the wall surface). At least 80 percent of the coating should

Figure 2: Test Procedure Diagram

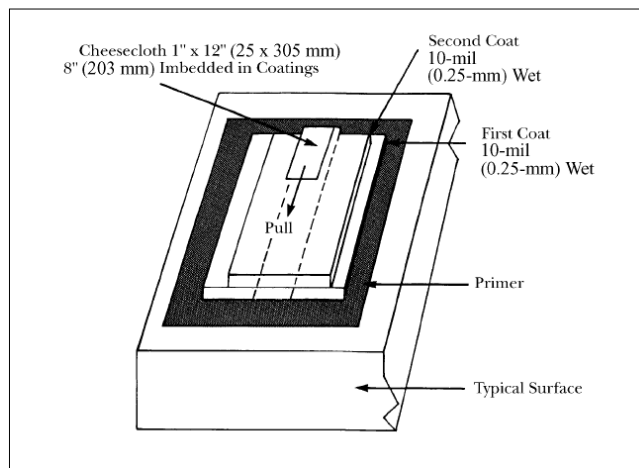

remain on the substrate. If the 80 percent retention is not achieved, reclean and test another suitable section. If necessary, contact Dow Corning Technical Service for further instruction. (Refer to Dow Corning's web site www.dowcorning.com for the location of the nearest Dow Corning Technical Service facility.)

7. If adhesion cannot be achieved, the test should be repeated using *Dow Corning*® AllGuard Primer.

Cleaning and Maintenance

1. Abrasive cleaners and cleaning equipment should never be used.
2. Routine cleaning is suggested, and dictated by the surrounding environment. Visible debris, such as airborne dirt or soot, should not be allowed to collect on the coating for a long period of time. This will increase cleaning effort and may be difficult to completely remove.
3. Recommended cleaning method involves the use of pressurized water and a basic cleaning agent such as trisodium phosphate (TSP) or *Simple Green*^{TM1}. Water pressure should not exceed 1,500 psi (10.3 MPa) to clean the surface without removing the coating material from the wall surface. A small test patch should be done first to determine how long the cleaning agent should be left on the surface before rinsing.
4. Stubborn marks may require the use of a soft bristle brush with the cleaning solution. Avoid stiff brushes that may abrade the coating.
5. Any touch-ups or repairs to the coating can be accomplished by applying *Dow Corning AllGuard Silicone Elastomeric Coating* to the clean, dry area according to the recommendations in this application guide.

¹Simple Green is a trademark of Sunshine Makers, Inc.

Limited Warranty

Unless Dow Corning issues a project-specific written warranty, Dow Corning warrants only that the goods meet Dow Corning's sales specifications at the time of shipment. **DOW CORNING EXPRESSLY DISCLAIMS ANY EXPRESS OR IMPLIED WARRANTY OF MERCHANTABILITY OR FITNESS FOR A PARTICULAR PURPOSE.** The buyer's exclusive remedy and Dow Corning's sole responsibility for any claim arising out of the purchase or use of these goods is expressly limited to either replacement of the nonconforming goods or refund of the purchase price within 90 days of the date of purchase.

Dow Corning offers a project-specific 10-Year Limited Performance Warranty when the *Dow Corning AllGuard Silicone Elastomeric Coating* is applied in accordance with Dow Corning's published application guidelines. Contact your Dow Corning Sales Representative for details or to apply for a project-specific warranty. Under this Limited Warranty, for a period of ten years from the date of purchase, Dow Corning will be responsible for the cost of replacement coating for any areas in which the *Dow Corning AllGuard Silicone Elastomeric Coating* fails to protect the above-grade substrate from through-water penetration and for the cost of labor to apply such replacement coating, up to a maximum of five times the cost of the replacement coating. Dow Corning's warranty is subject to certain restrictions and does not cover faults attributable to workmanship or the appearance of the coating.

NOTE: No warranty is available when *Dow Corning AllGuard Silicone Elastomeric Coating* is used on a single-family residential dwelling.

How to Contact Us

Dow Corning has sales offices and manufacturing sites as well as science and technology laboratories around the globe. Telephone numbers of locations near you are available on the internet at www.dowcorning.com, or by calling one of our primary locations listed here.

Your Global Connection

Asia

Dow Corning Asia Ltd. – Japan
Tel +81 3 3287 1151

Dow Corning Asia – Singapore
Tel: +65 253 6611

Australia & New Zealand

Dow Corning Australia Pty. Ltd.
Tel: +61 1300 360 732

Europe

Dow Corning Europe
Tel: +32 64 88 80 00

North America

Dow Corning Corporation
World Headquarters
Tel: +1 989 496-6000

South America

Dow Corning do Brasil
Tel: +55 11 3759 4300

Handling Precautions

PRODUCT SAFETY INFORMATION REQUIRED FOR SAFE USE IS NOT INCLUDED IN THIS DOCUMENT. BEFORE HANDLING, READ PRODUCT AND MATERIAL SAFETY DATA SHEETS AND CONTAINER LABELS FOR SAFE USE, PHYSICAL AND HEALTH HAZARD INFORMATION. THE MATERIAL SAFETY DATA SHEET IS AVAILABLE FROM YOUR DOW CORNING REPRESENTATIVE, OR DISTRIBUTOR, OR BY CALLING YOUR GLOBAL DOW CORNING CONNECTION.

Limited Warranty Information – Please Read Carefully

The information contained herein is offered in good faith and is believed to be accurate. However, because conditions and methods of use of our products are beyond our control, this information should not be used in substitution for customer's tests to ensure that Dow Corning's products are safe, effective, and fully satisfactory for the intended end use. Suggestions of use shall not be taken as inducements to infringe any patent.

Dow Corning's sole warranty is that the product will meet the Dow Corning sales specifications in effect at the time of shipment.

Your exclusive remedy for breach of such warranty is limited to refund of purchase price or replacement of any product shown to be other than as warranted.

DOW CORNING SPECIFICALLY DISCLAIMS ANY OTHER EXPRESS OR IMPLIED WARRANTY OF FITNESS FOR A PARTICULAR PURPOSE OR MERCHANTABILITY.

DOW CORNING DISCLAIMS LIABILITY FOR ANY INCIDENTAL OR CONSEQUENTIAL DAMAGES.